

## SPECIFICATIONS

<b>GENERAL</b>	<b>Semiconductors:</b> .....	41 transistors, 1 FET, 58 diodes, 6 ICs and 2 LEDs
	<b>Frequency Range:</b> .....	26.965 MHz – 27.405 MHz (channels 1 through 40)
	<b>Antenna Impedance:</b> .....	50 ohms
	<b>Modulation:</b> .....	AM (Amplitude Modulation)
	<b>Channel Display:</b> .....	7-segment LED x 2
	<b>Controls:</b> .....	Volume Control with Power Switch Squelch Control RF Gain Control Mode Selector Switch Clarifier Control PA-CB Switch ANL/NB + ANL Switch Channel Selector Switch
	<b>Connectors and Jacks:</b> .....	Microphone connector SO-239 Antenna connector (50 ohms) Public Address Speaker Jack (8 ohms) External Speaker Jack (8 ohms) 13.8V DC Power Jack
	<b>Speaker</b> .....	3-½ inch, 8 ohms
	<b>Microphone:</b> .....	Dynamic microphone (600 ohms)
	<b>Power Supply:</b> .....	13.8 volts DC (Positive or Negative Ground)
	<b>Dimensions:</b> .....	7-1/4"(W) x 2-¼"(H) x 9"(D) 18.4 cm(W) x 5.7 cm(H) x 22.9 cm(D)
	<b>Weight:</b> .....	4 lbs. 5 oz. (2 kg.)

### RECEIVER NOMINAL SPECIFICATIONS

<b>Circuit:</b> .....	PLL synthesized dual conversion superheterodyne
<b>IF Frequency:</b> .....	1st IF ..... 10.695 MHz, 2nd IF ..... 455 kHz
<b>Sensitivity at S/N 10 dB:</b> .....	AM 0.5 $\mu$ V, SSB 0.25 $\mu$ V
<b>Selectivity:</b> .....	( $\pm$ 10 kHz) 60 dB
<b>AGC:</b> .....	80 dB
<b>S/N at 1mV input:</b> .....	35 dB
<b>Audio Power Output:</b> .....	4 watts
<b>Audio Frequency Response:</b> .....	300 – 3.5 kHz
<b>Spurious Response:</b> .....	-60 dB
<b>Squelch Range:</b> .....	0.5 $\mu$ V to 1000 $\mu$ V
<b>Current Drain (no signal):</b> .....	250 mA

### TRANSMITTER NOMINAL SPECIFICATIONS

<b>RF Output Power:</b> .....	AM 4W, SSB 12W PEP maximum
<b>Modulation Capability:</b> .....	100% maximum
<b>Spurious Response:</b> .....	-70 dB

#### NOTE

Repair or adjustment of transmitter circuits must be under supervision of a person with first-or second-class radiotelephone license.  
(Refer to FCC Rules and Regulations Part 95, Subpart C & D.)

The frequency of the transmitter should be checked periodically with a secondary frequency standard to insure proper and legal operation.

Best results will be obtained when adjusting the final RF output circuit if the antenna normally used is connected and the chassis is as nearly in the cabinet as possible.

Connect either 50-ohm dummy load or the normally used antenna system.

## ALIGNMENT OF RECEIVER SECTION

### 1. Equipment Required:

- a. RF Signal Generator (27 MHz Band, 50 ohm output impedance)
- b. AF VTVM
- c. Oscilloscope
- d. DC Power Supply
- e. 8 ohm load

### 2. Procedure

Connect Test Equipment as shown below.

Step	Preset To	Adjustment	Remarks
1	CH: 19, PA/CB: CB, CLARI: Center, AF VOL: Fully CW, RF VOL: Fully CW, SQUELCH: Fully CCW, NB/ANL: OFF.		Set the SG on CH19, 27.185 MHz with 1 KHz 30% modulation.
2	Same as step 1	L-10, 9, 8, 7, 6, 5, 4 and 3.	Adjust coils to obtain 2V reading on AF VTVM. Then repeat this adjustment several times.
3	Same as step 1	L-8 and L-9.	Turn the core of L-8 in the full CW. position. Adjust L-9 for maximum reading. Adjust L-8 for maximum reading. Then readjust L-8 to keep the difference of sensitivity within 1 dB between CH1 and CH40.
4	Same as step 1 SQUELCH: Fully CW.	VR-2	Set the SG to 1000 $\mu$ V then adjust VR-2 till AF signal is observed on oscilloscope.
5	Same as step 1	VR-1	Set the SG to 100 $\mu$ V with no modulation then adjust VR-1 to obtain "S-9" reading on Transceiver's meter.
6	Same as step 1	L-1 and L-2	Set the oscilloscope for DC operation. Adjust SG to approx. 1.6 $\mu$ V then adjust coils for maximum reading on oscilloscope.

## RECEIVER TEST EQUIPMENT CONNECTIONS

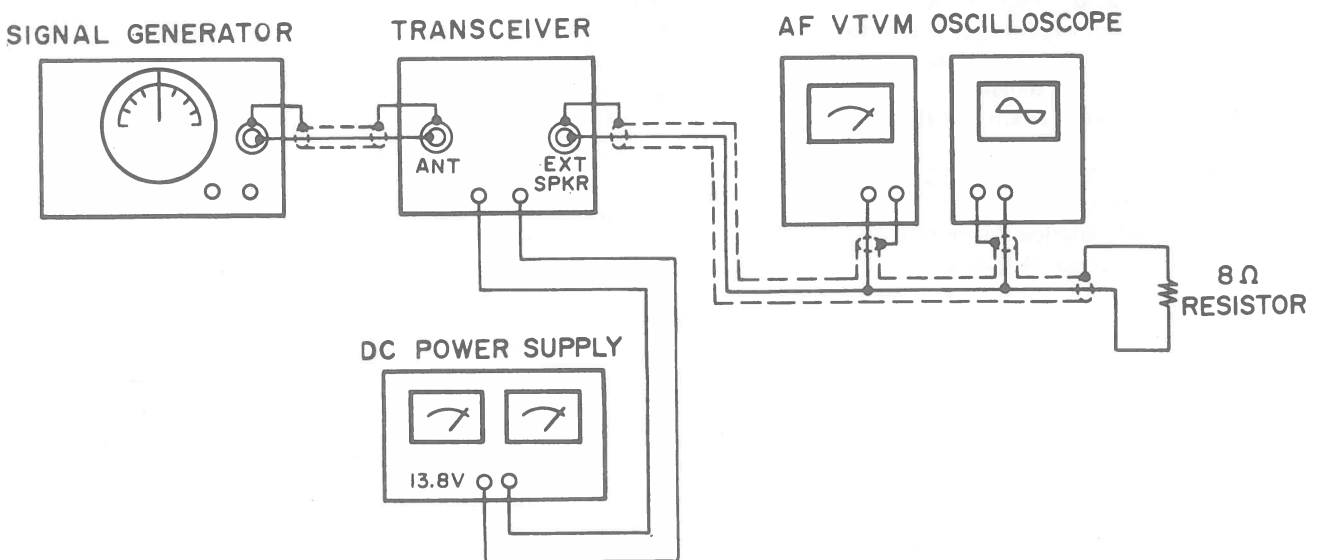

# ADJUSTMENTS AND TEST POINTS

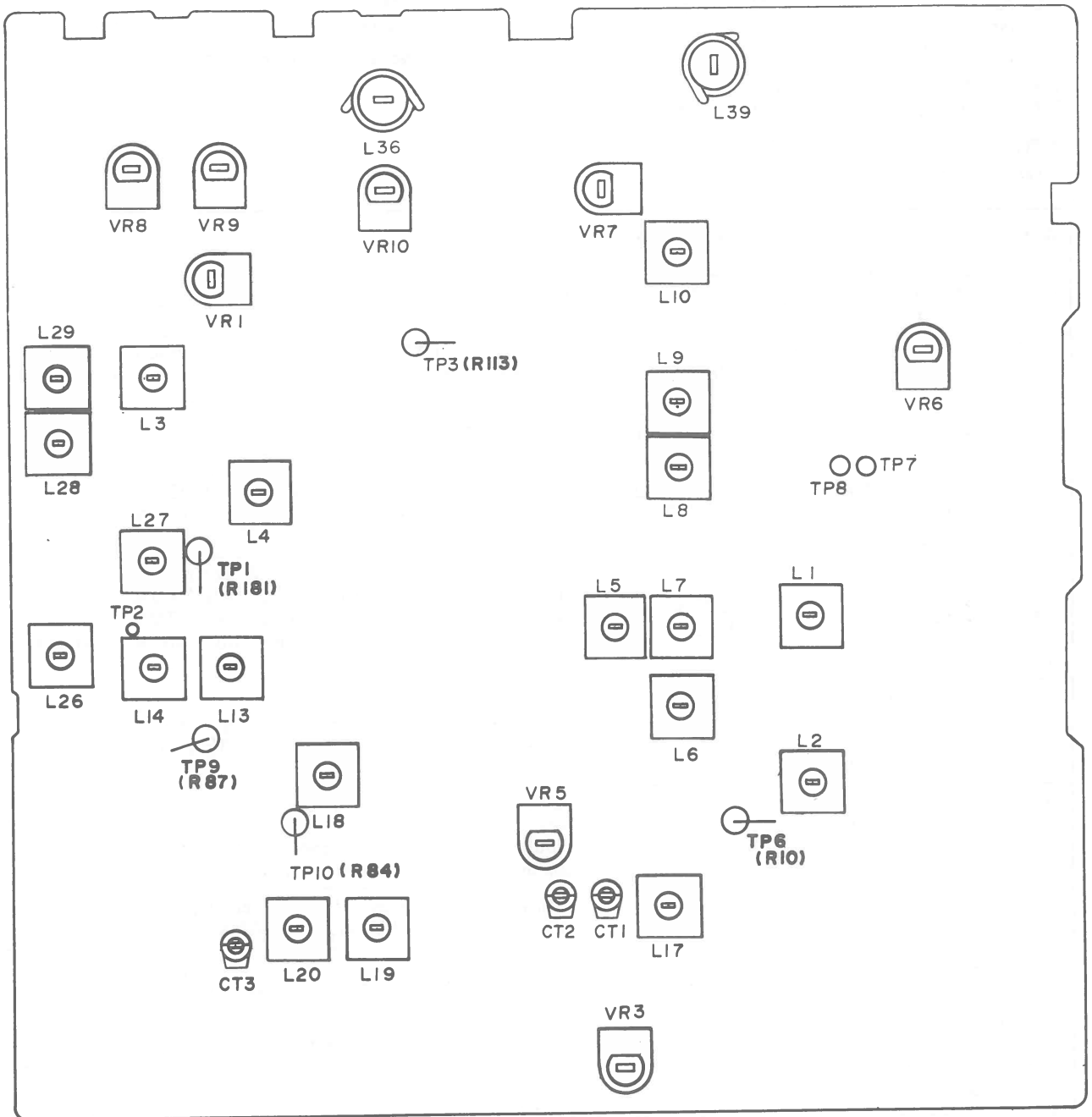

## ALIGNMENT OF TRANSMITTER SECTION

### 1. Equipment Required:

- |  |                                    |
|--|------------------------------------|
| a. AF Oscillator (two required)                                      | g. Oscilloscope                    |
| b. AF VTVM (Full scale: 1V DC with RF probe)                         | h. RV VTVM                         |
| c. DC Ammeter  | i. Harmonic Meter                  |
| d. RF Power Meter  | j. DC Power Supply (13.8 V/3 amp.) |
| e. 50 ohm load and Attenuator  |                                    |
| f. AF Attenuator, 600-ohm, attenuation range 0 – 80 dB, 0.1 dB step. |                                    |

### 2. Procedure

Connect Test Equipment as shown below.

Step	Preset To	Adjustment	Remarks
1	CH: 19, PA/CB: CB USB mode, TX S1 and S2: OFF	VR-8	Break circuit at TP-8, place DC mA meter in series. Adjust for 30mA $\pm 5$ mA. If it is not reached to 30 mA, set the VR-8 for fully CCW.
2	Same as step 1	VR-9	Break circuit at TP-7, place DC mA meter in series. Adjust for 60mA $\pm 5$ mA. If 60 mA can not be attained, set VR-9 for fully CW.
After STEP 1 and STEP 2, restore circuit at TP-8 and TP-7.			
3	Same as step 1 OSC 1: 500 Hz OSC 2: 2400 Hz S1 and S2: ON	L-26, 27, 28 and L-29	Reduce the AF ATT to maintain the 15V-20V range on the RF VTVM, while adjusting coils for peak reading.
4	Same as step 3	L-29 and L-28	Turn the core of L-29 in the full CW. position. Adjust L-28 for maximum reading on RF VTVM. Adjust L-29 for maximum reading on RF VTVM. Then readjust L-29 to keep the RF output voltage reading on CH1 and CH40 within 1V.
5	Same as step 1 AM mode OSC 1: 1 KHz S1: ON, S2: OFF.	L-36	Adjust level of OSC 1 for 5mV reading on AF VTVM, then adjust L-36 for maximum reading on RF VTVM.
6	Same as step 1 S1 and S2: OFF	VR-5	Adjust for minimum carrier leakage for both USB and LSB on oscilloscope. Note: Connect the oscilloscope to the Antenna Connector of the unit. 50 $\Omega$ Load must be connected to antenna.
7	Same as step 3	VR-7	Adjust OSC 1 and OSC 2 for 5mV reading on AF VTVM then adjust VR-7 for 24.5V reading on RF VTVM.
8	Same as step 1 AM mode S1 and S2: OFF.	VR-6	Adjust for 4.0W reading on RF Power meter.
9	Same as step 8	VR-10	Adjust for reading of 4W on the Transceiver's meter.
10	Same as step 8	L-39	Adjust for minimum 2'nd harmonic (54 MHz) on Harmonic meter.

**TRANSMITTER TEST EQUIPMENT CONNECTIONS**

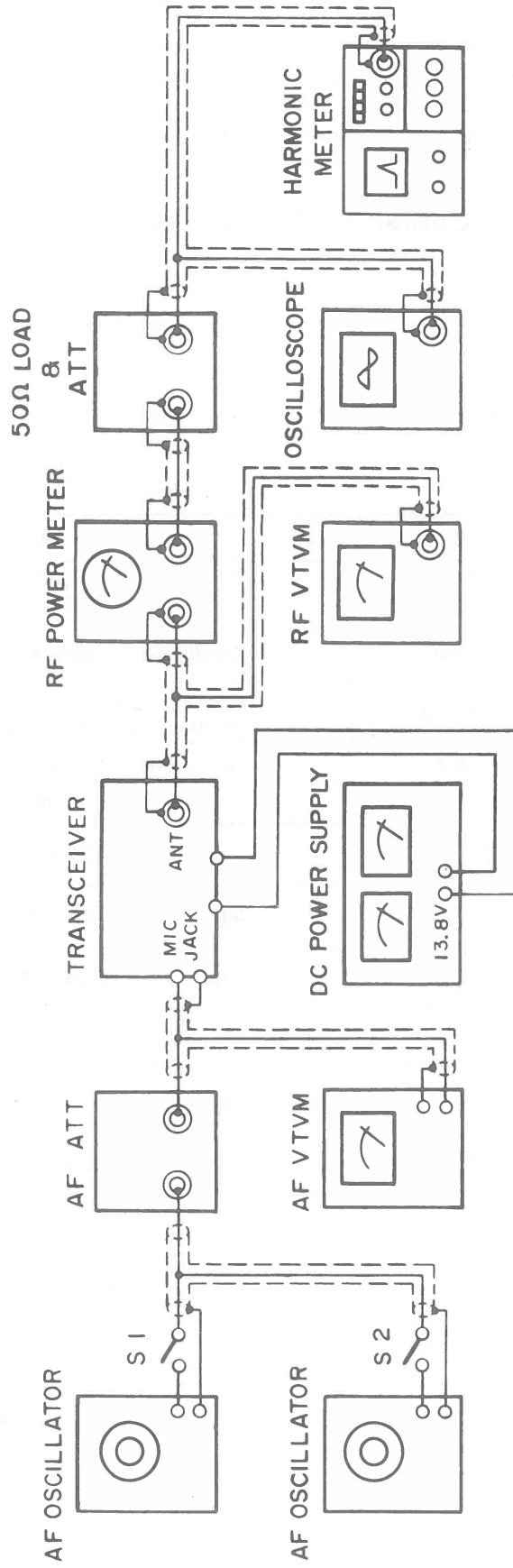

## PUBLIC ADDRESS

Signal from the MIC is preamplified by TR29 and TR28 and then goes to TR36 after being amplified in TR30, PA Switching Transistor. The signal is amplified by IC4 and activates a PA speaker.

**NOTE** Repair or adjustment of transmitter circuits must be under supervision of a person with first-or second-class radiotelephone license.  
(Refer to FCC Rules and Regulations Part 95, Subpart C & D.)

## ALIGNMENT OF PLL AND CARRIER OSCILLATOR

### 1. Test equipment required:

- a. Oscilloscope (DC – 50 MHz)
- b. Frequency counter (0 – 30 MHz)
- c. DC Power Supply (13.8V 100 mA)
- d. DC Voltmeter (10V Maximum 100K ohm/V)
- e. 50 ohm Load

### 2. Alignment procedure:

Connect Test Equipment as shown below.

Step	Preset To	Connection	Adjustment
1	CH: 40, USB, RX, Clarifier in center	TP-9 (lead of R-181)	Adjust L-13 for a 6.5V DC reading on oscilloscope. (oscilloscope in DC operation)
2	Same as step 1. CH: 1.	TP-9	Check for more than 4V DC reading on oscilloscope.
3	Same as step 1. CH: 19.	TP-10	Adjust L-18 for maximum reading on oscilloscope. (oscilloscope in AC operation)
4	Same as step 3.	TP-1	Adjust L-14 for maximum reading on oscilloscope.
5	Same as step 3.	TP-1	Adjust CT-3 for 34.987500 MHz $\pm 20$ Hz.
6	Same as step 1. CH: 19, AM.	TP-1	Adjust L-20 for 34.985000 MHz $\pm 20$ Hz.
7	Same as step 1. CH: 19, LSB.	TP-1	Adjust L-19 for 34.9825 MHz $\pm 20$ Hz.
8	Same as step 1. CH: 19, LSB, TX.	TP-1	Adjust VR-3 for 34.9825 MHz $\pm 20$ Hz.
9	Same as step 1. CH: 19, LSB.	TP-3	Adjust CT-2 for 7.797500 MHz $\begin{matrix} +0 \\ -5 \end{matrix}$ Hz.
10	Same as step 1. CH: 19, USB.	TP-3	Adjust CT-1 for 7.802500 MHz $\begin{matrix} +5 \\ -0 \end{matrix}$ Hz.
11	Same as step 1. CH: 19, TX.	TP-3	Adjust L-17 for 7.800000 MHz $\pm 5$ Hz.

PLL AND CARRIER OSCILLATOR TEST EQUIPMENT CONNECTIONS

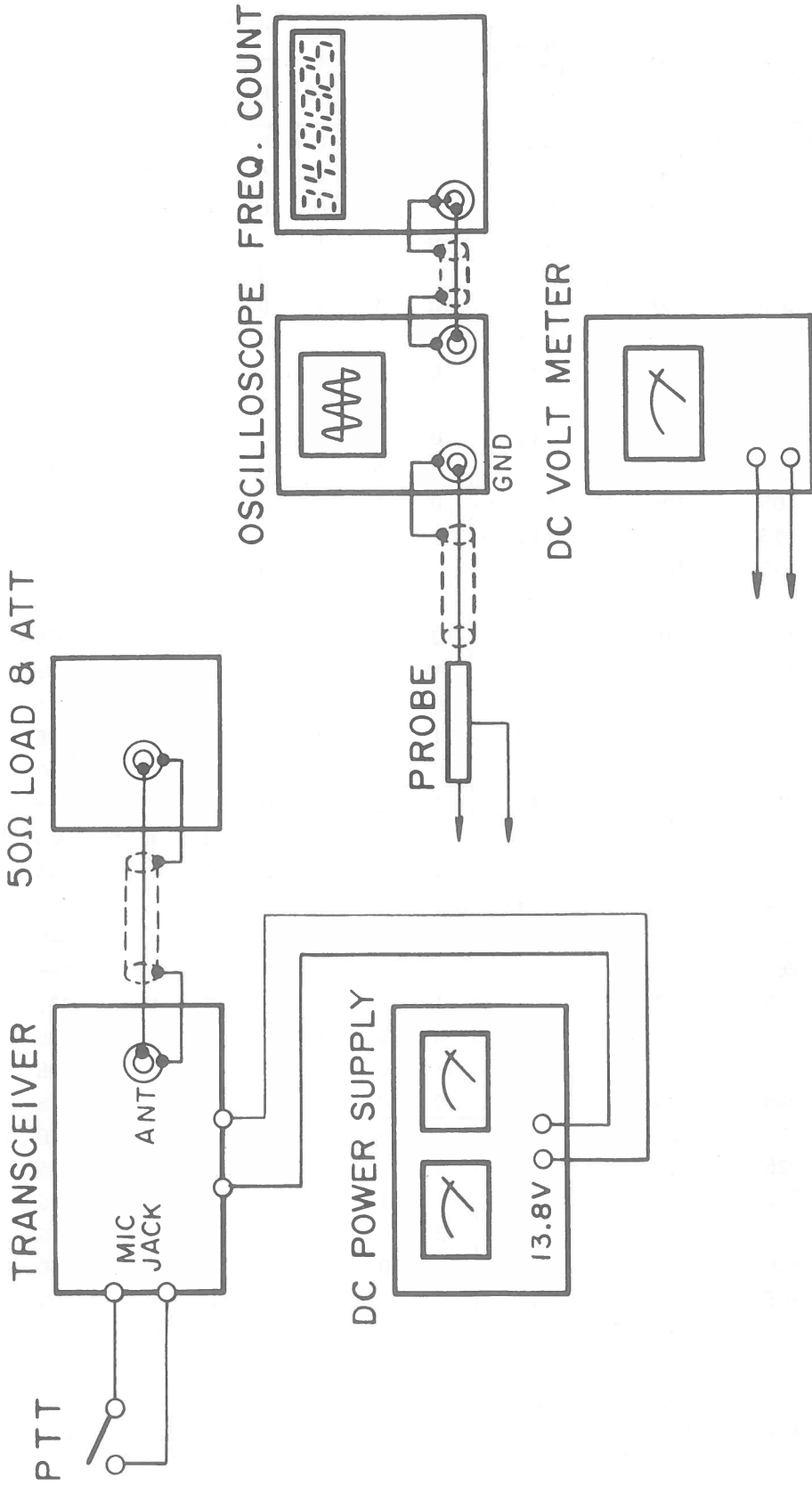

# FREQUENCY CHART OF PLL

CH	Channel frequency (MHz)	Divide ratio (N)	1/N Input Frequency at TP-10 (MHz)	Program input at IC-2						Local oscillator frequency at TP-1 (MHz)		
				P1	P2	P3	P4	P5	P6	AM mode	USB mode	LSB mode
1	26.965	91	0.91	1	0	0	0	0	0	34.765	34.7675	34.7625
2	.975	92	0.92	0	1	0	0	0	0	.775	.7775	.7725
3	.985	93	0.93	1	1	0	0	0	0	.785	.7875	.7825
4	27.005	95	0.95	0	0	1	0	0	0	.805	.8075	.8025
5	.015	96	0.96	1	0	1	0	0	0	.815	.8175	.8125
6	.025	97	0.97	0	1	1	0	0	0	.825	.8275	.8225
7	.035	98	0.98	1	1	1	0	0	0	.835	.8375	.8325
8	.055	100	1.00	0	0	0	1	0	0	.855	.8575	.8525
9	.065	101	1.01	1	0	0	1	0	0	.865	.8675	.8625
10	.075	102	1.02	0	0	0	0	1	0	.875	.8775	.8725
11	.085	103	1.03	1	0	0	0	1	0	.885	.8875	.8825
12	.105	105	1.05	0	1	0	0	1	0	.905	.9075	.9025
13	.115	106	1.06	1	1	0	0	1	0	.915	.9175	.9125
14	.125	107	1.07	0	0	1	0	1	0	.925	.9275	.9225
15	.135	108	1.08	1	0	1	0	1	0	.935	.9375	.9325
16	.155	110	1.10	0	1	1	0	1	0	.955	.9575	.9525
17	.165	111	1.11	1	1	1	0	1	0	.965	.9675	.9625
18	.175	112	1.12	0	0	0	1	1	0	.975	.9775	.9725
19	.185	113	1.13	1	0	0	1	1	0	.985	.9875	.9825
20	.205	115	1.15	0	0	0	0	0	1	35.005	35.0075	35.0025
21	.215	116	1.16	1	0	0	0	0	1	.015	.0175	.0125
22	.225	117	1.17	0	1	0	0	0	1	.025	.0275	.0225
23	.255	120	1.20	1	1	0	0	0	1	.055	.0575	.0525
24	.235	118	1.18	0	0	1	0	0	1	.035	.0375	.0325
25	.245	119	1.19	1	0	1	0	0	1	.045	.0475	.0425
26	.265	121	1.21	0	1	1	0	0	1	.065	.0675	.0625
27	.275	122	1.22	1	1	1	0	0	1	.075	.0775	.0725
28	.285	123	1.23	0	0	0	1	0	1	.085	.0875	.0825
29	.295	124	1.24	1	0	0	1	0	1	.095	.0975	.0925
30	.305	125	1.25	0	0	0	0	1	1	.105	.1075	.1025
31	.315	126	1.26	1	0	0	0	1	1	.115	.1175	.1125
32	.325	127	1.27	0	1	0	0	1	1	.125	.1275	.1225
33	.335	128	1.28	1	1	0	0	1	1	.135	.1375	.1325
34	.345	129	1.29	0	0	1	0	1	1	.145	.1475	.1425
35	.355	130	1.30	1	0	1	0	1	1	.155	.1575	.1525
36	.365	131	1.31	0	1	1	0	1	1	.165	.1675	.1625
37	.375	132	1.32	1	1	1	0	1	1	.175	.1775	.1725
38	.385	133	1.33	0	0	0	1	1	1	.185	.1875	.1825
39	.395	134	1.34	1	0	0	1	1	1	.195	.1975	.1925
40	.405	135	1.35	0	0	0	0	0	0	.205	.2075	.2025

0: Low level (0-1 V)

1: Hi level (3.5-6 V)

MAIN P.C.BOARD (TOP VIEW)

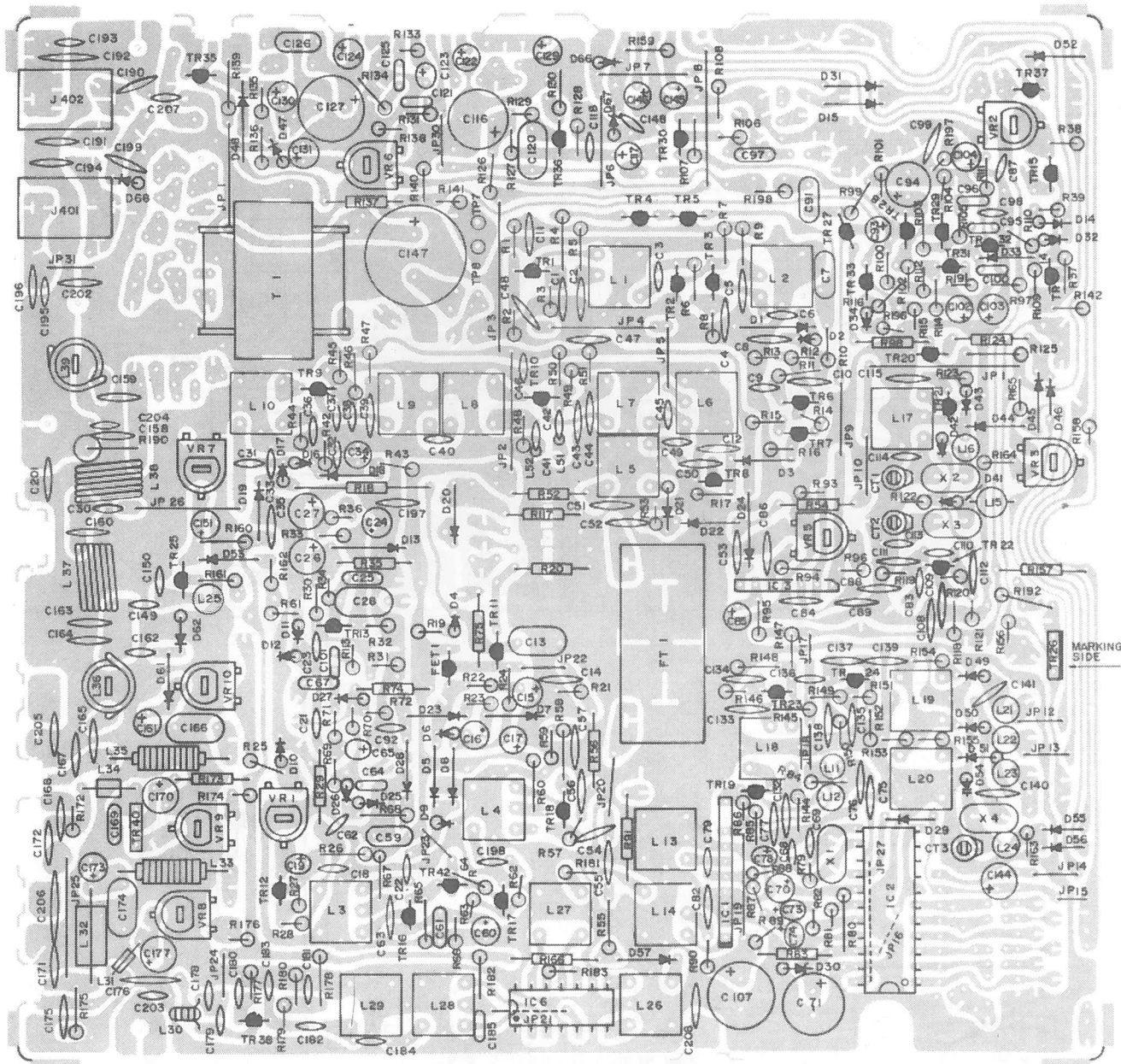

WIRING DIAGRAM OF MAIN P.C.BOARD AND ADDITIONAL PARTS ON BOTTOM

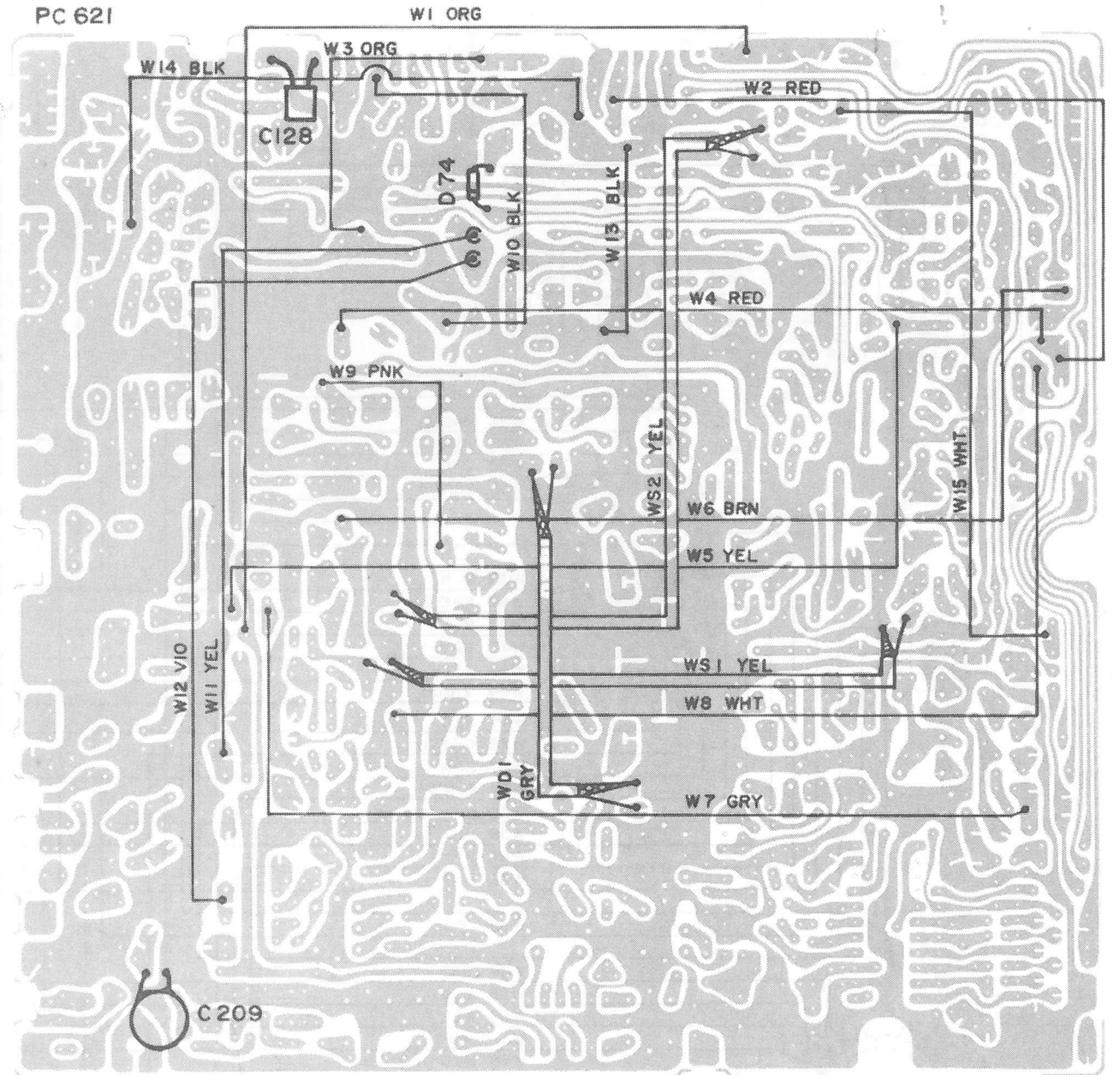

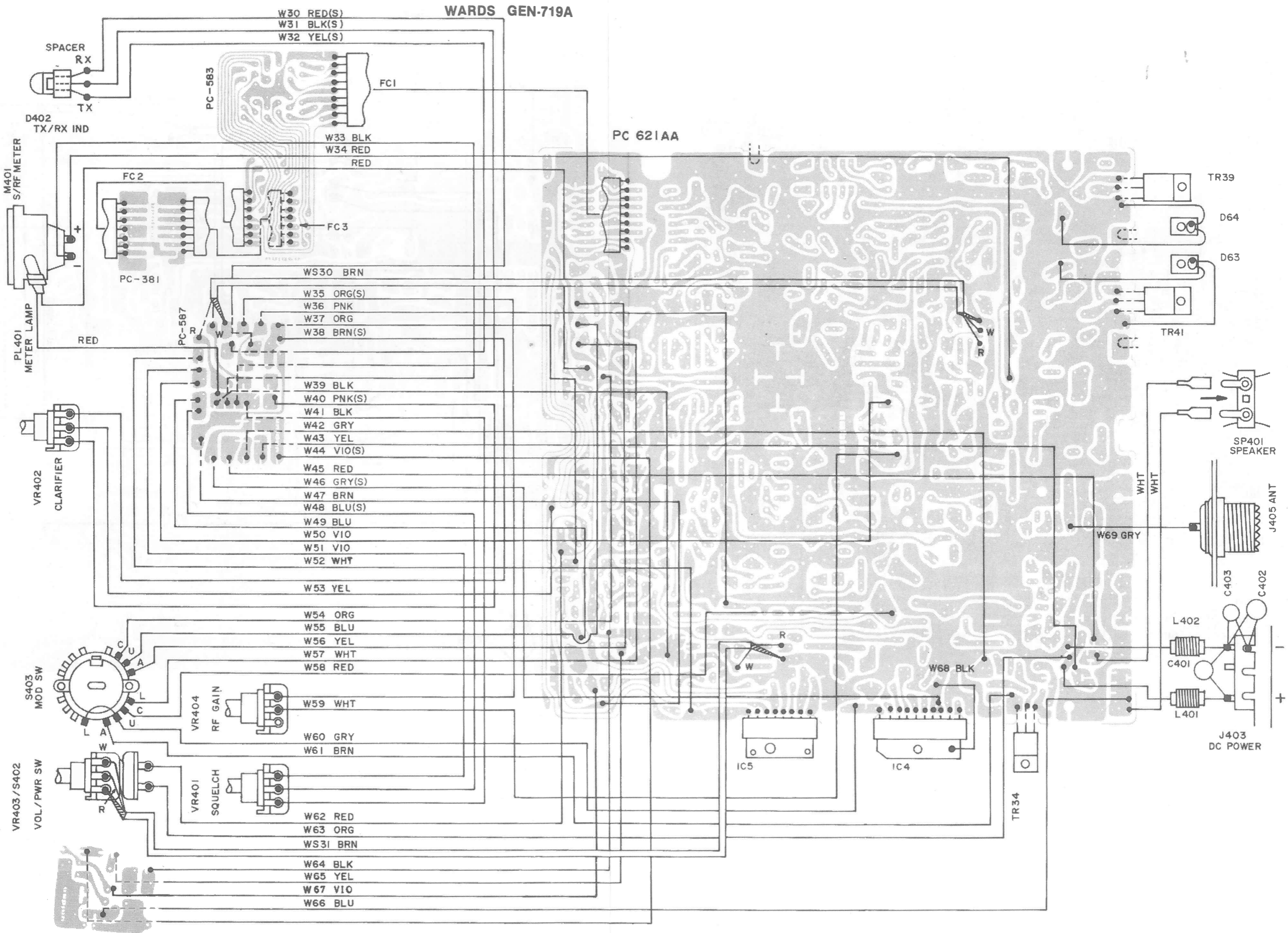

PARTS LAYOUT DRAWINGS

CH SW PCB

PC 583

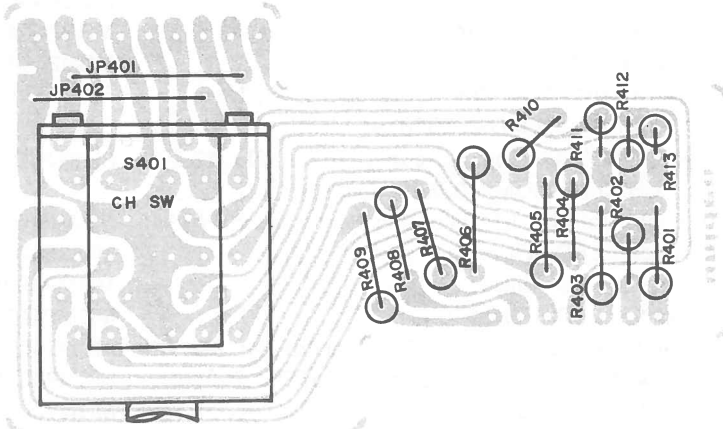

CH LED PCB

PC 381

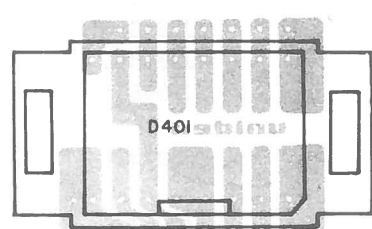

SLIDE SW PCB

PC 587

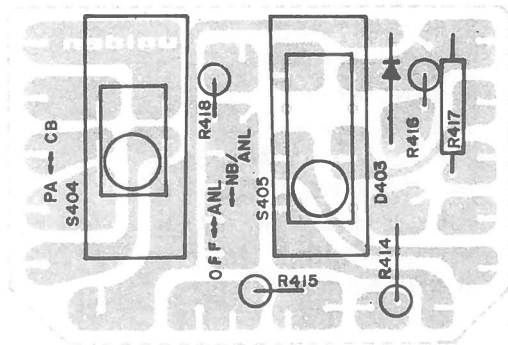

MIC JACK PCB

PC 389

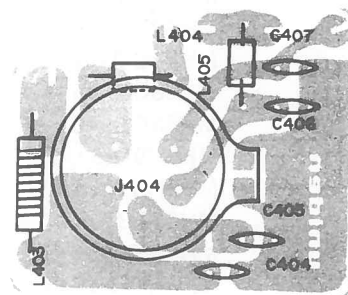

REF. NO.	PART NO.	DESCRIPTION	MFRS. PART CODE
	J381610	Chassis Assembly (Inc. Ref. #20 and chassis MDBC205978)	WAKU534Z-A
	J70954	Cabinet Top Cover	MDBP205979
	J70955	Cabinet Bottom Cover	MDBP205980
	J381611	Unit Mounting Bracket	MDBP406058
	J381612	Chassis Panel, Front	MDBP307818
	J381613	Microphone Mounting Bracket	MDBP402919
	J261020	Terminal Strip (Metal), Ground	MDBP405562
	J381614	Bracket, Meter Holding	MDBP404022
	J381615	Bracket, S401 Mounting	MDBP404024
	J70956	Front Panel Ass'y (Inc. Ref. Nos. 16, 17, 19 and Front Panel MDMP207819)	FPANEL534Z
	J501301	Knob Ass'y Channel Selector (Inc. Ref. No. 42 and CH Knob MDMP403855)	CHKNOB534Z
	J501302	Knob, Volume, RF Gain, Clarifier, Squelch, Mode	MDMP401728
	J64252	Holder, LED (Violet)	MDMP404790
	J64253	Holder, LED (Black)	MDMP403857
	J64254	Holder, LED, Rubber (Black)	MDMP407400
	N.A. Separately	Nameplate, Control, A1P 0.5t (Part of Ref. No. 10)	MDNP407820
	N.A. Separately	Nameplate, Brand, A1P 0.5t (Part of Ref. No. 10)	MDNP407821
	J15127	F.C.C. I.D. Plate	MDNP407822
	N.A. Separately	Panel, Front Display, 1.0t (Part of Ref. No. 10)	MDAP407823
	N.A. Separately	Supporter, Mounting Bracket (Part of Ref. No. 1)	MDHP403988
	J381616	Cushion, Meter Mounting	MDZP404326
	J471710	Screw, Pan Hd, Plastic, M3 x 6	MZSS123006
	MHSCC 3 x 8	Screw, Flat Hd, Ni, M3 x 8	MZSN133008
	MHSBC 2 x 5	Screw, Bind Hd, Ni, M2 x 5	MZSN192005
	MHSBC 2.6 x 4	Screw, Bind Hd, Ni, M2.6 x 4	MZSN192604
	MHSBC 2.6 x 6	Screw, Bind Hd, Ni, M2.6 x 6	MZSN192606
	MHSBC 2.6 x 10	Screw, Bind Hd, Ni, M2.6 x 10	MZSN192610
	MHSBC 3 x 6	Screw, Bind Hd, Ni, M3 x 6	MZSN193006
	MHSBC 3 x 8	Screw, Bind Hd, Ni, M3 x 8	MZSN193008
	MHSHB 3.5 x 8	Tapping Screw, Round Hd, ZMC, 3.5 $\phi$ x 8	MZSZ293508
	MHSHB 5 x 10	Tapping Screw, Round Hd, ZMC, 5 $\phi$ x 10	MZSZ295010
	MHSJC 3 x 8	Tap Tight Screw, Bind Hd, ZMC, M3 x 8	MZSZ343008
	MHNVC 2.6 x 5	Nut, Hex, Ni, M2.6 x 5	MZSN430026
	MHNVC 3.5 x 5	Nut, Hex, Ni, M3 x 5.5	MZSN430030
	J471711	Nut, Flange, ZMC, M3	MZSZ480030
	J471712	Screw, Unit Mounting Bracket	MDMC405736
	J421057	Washer, Rubber, Unit Mtg. Bracket	MDZP400638
	J421058	Washer, Spring, Ni, 2.6 $\phi$	MZSN510026
	MHNTB 3.5 x 7.3	Washer, Lock, ZMC, 3.5 $\phi$ x 7.3	MZSZ530035
	MHNTB 5 x 9.8	Washer, Star, ZMC, 5 $\phi$ x 9.8	MZSZ540050
	J261031	Terminal, Lug, Solder	MZTT150003
	N.A. Separately	Spring Plate, Knob (Part of Ref. No. 11)	MZTT200003
	J471713	Rivet, AL, ID Plate, 3 $\phi$ x 5	MZTT213250
	J75284	Packing Cushion, Top	MDPP204869
	J75285	Packing Cushion, Bottom	MDPP304870
	J75286	Individual Carton Box	MDPP307824
	J59266	Owner's Guide	MZPZ543001
	E591948	Warranty Card	MZPZ534004
	J59237	FCC Rules Part 95, Subpart D	MZPY000025
	J381617	Hardware Kit (Includes: Ref. Nos. 31 (2 pcs.) 40 (2 pcs.), 30 (2 pcs.), 39 (2 pcs.), 6 (1 pc.) in plastic bag)	HWK-534Z

REF. NO.	PART NO.	DESCRIPTION	MFR PART CODE
<b>SEMICONDUCTORS</b>			
IC1	UHIC070	Integrated Circuit, UHIC070	DDEY133001
IC2	$\mu$ PD2824C	Integrated Circuit, $\mu$ PD2824C	DDEY190001
IC3	AN612	Integrated Circuit, AN612	DDEY130001
IC4	TA7222P	Integrated Circuit, TA7222P	DDEY146001
IC5	MB3756	Integrated Circuit, MB3756	DDEY131001
IC6	SO42P	Integrated Circuit, SO42P	DDEY132001
FET1	2SK19(BL)	Field Effect Transistor, 2SK19BL	DDCY001002
TR1, 2, 6, 10, 12, 21, 22, 24, 25, 42	2SC710(C)	Transistor, 2SC710C	DDBY209001
TR3, 8, 16	2SC1730(L)	Transistor, 2SC1730L	DDBY269001
TR4, 5, 11, 13, 15, 20, 27, 32, 33, 35, 37	2SC711(E)	Transistor, 2SC711E	DDBY210002
TR7, 14, 30, 31	2SA628(F)	Transistor, 2SA628F	DDBY019001
TR9	2SC1674(L)	Transistor, 2SC1674L	DDBY295002
TR17, 18	2SC763(C)	Transistor, 2SC763C	DDBY216001
TR19, 23	2SC1675(L)	Transistor, 2SC1675L	DDBY259001
TR26, 40	2SC496(O)	Transistor, 2SC496-O	DDBY246001
TR28	2SC945A(Q)	Transistor, 2SC945AQ	DDBY224003
TR29, 36	2SC1312(F)	Transistor, 2SC1312F	DDBY317001
TR34	2SC1419(C)	Transistor, 2SC1419C	DDBY278001
TR38	2SC1973	Transistor, 2SC1973	DDBY272001
TR39	2SC1306	Transistor, 2SC1306	DDBY230001
TR41	2SC1969(B)	Transistor, 2SC1969B	DDBY307001
D1, 2, 9, 25, 26, 48	1N60	Diode, 1N60	DDAY001004
D3, 4, 5, 6, 7, 8, 10, 11, 12, 13, 14, 15, 18, 19, 20, 21, 22, 23, 24, 27, 28, 29, 31, 32, 33, 34, 41, 42, 43, 44, 45, 46, 47, 49, 50, 51, 52, 53, 55, 56, 57, 61, 62, 74, 403	1S2075(K)	Diode, 1S2075K	DDAY063001
D16, 17	MC301	Diode, MC301	DDAY090001
D30	RD5, 1EB2	Diode, Zener, RD-5. 1E-B2	DDAY086014
D54	1S2687(D)	Diode, Vari-Cap, 1S2687D	DDAY067001
D63	MV13YH	Varistor, MV13YH	DDFY021001
D64	MV1Y	Varistor, MV1Y	DDFY020001
D66, 68	1N4003	Diode, 1N4003	DDAY133001
D67	RD20EB1	Diode, Zener, RD-20E-B-1	DDAY086012
D401	UR202	Diode, LED, UR202	DDAY113001
D402	TLRG101	Diode, LED, TLRG101	DDAY102001

# TRANSISTOR AND IC PIN CONFIGURATIONS

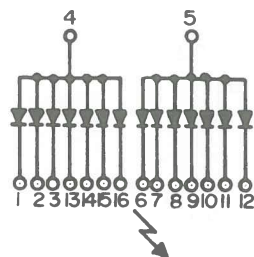
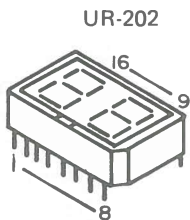
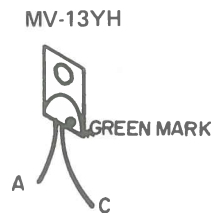
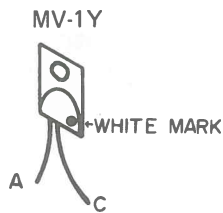
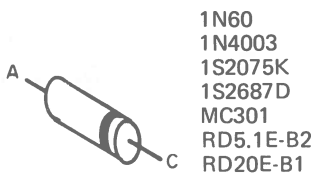
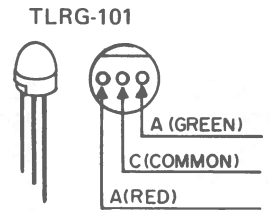
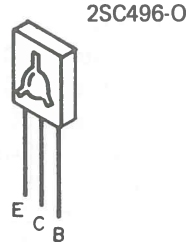
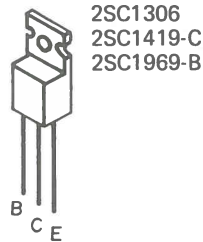
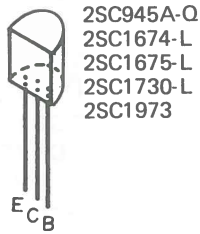
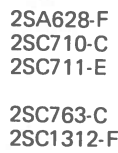
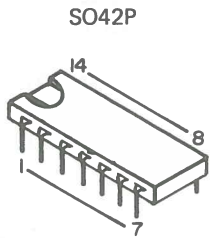
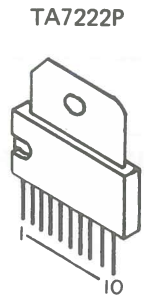
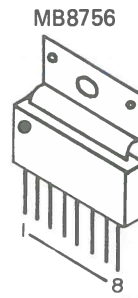
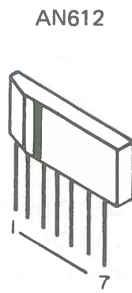
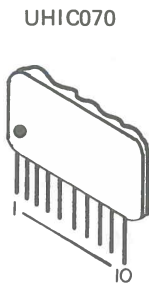
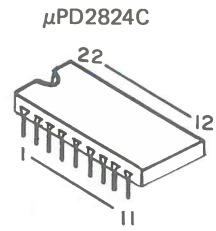

NOTE

FET D — DRAIN  
S — SOURCE  
G — GATE

TR E — EMITTER  
C — COLLECTOR  
B — BASE

DIODE A — ANODE  
C — CATHODE

**VOLTAGE CHART**

CONDITION: Measured at Channel 19, No signal.

**BIPOLAR TRANSISTOR**

No.	Emitter	Base	Collector	Remarks
TR 1	0.5	1.2	7.8	RX, NB switch ON
2	0	0.7	2.4	RX, NB ON
3	1.6	2.4	6.8	RX, NB ON
4	0.5	0.5	8.0	RX, NB ON
5	0.5	0.4	8.0	RX, NB ON
6	0	0	7.4	RX, NB ON
7	8.0	7.4	0	RX, NB ON
8	0	0	0	
9	1.5	2.2	7.9	RX, RF Gain C.W.
	0	0.5	8.0	RX, RF Gain C.C.W.
10	0.1	0.3	7.9	RX
11	2.2	2.8	2.2	RX
	0	0	7.4	TX
12	0	0.5	8.0	RX
13	0.7	1.3	4.7	RX, SQ, C.C.W.
	1.7	1.4	7.9	RX, SQ, C.W.
14	8.0	8.0	0.7	RX, SQ, C.C.W.
	8.0	7.4	8.0	RX, SQ, C.W.
	0	0	0	TX
15	0.6	0	8.0	RX, SQ, C.C.W.
	1.1	2.5	7.4	RX, SQ, C.W.
16	2.1	2.9	7.1	RX
17	0	0.8	3.6	RX
18	1.5	2.2	6.8	RX
19	3.3	4.0	8.0	
20	0	0	7.5	TX, AM
	0	0	0.2	RX, AM
	0	0.8	0	TX and RX, SSB
21	0	0.8	0	TX, AM
	0	0.2	0	RX, AM
	0	0.1	0.3	TX and RX, USB only
	0	0.1	0	TX and RX, LSB only
22	1.6	2.3	7.6	
23	0.9	1.4	8.0	
24	2.8	3.5	6.5	
25	0	0	6.5	RX
	3.4	0	6.5	TX, AM
	1.6	0	6.5	TX, SSB
26	7.3	8	13.8	
	0.4	0.7	13.8	PA only
27	0	0.2	2.9	RX, AM
	0	0	2.9	RX, SSB
	1.3	1.9	1.3	TX, AM
	0	0.1	2.8	TX, SSB
28	1.1	1.7	3.2	
29	0.3	1.0	1.7	
30	3.2	3.2	0	
	2.2	1.5	2.2	PA only
31	6.9	6.6	0.7	RX
	6.9	6.6	0	TX
32	0	0.7	0	RX
33	4.1	0.8	6.5	
	1.4	0.7	6.5	RX, AM only

No.	Emitter	Base	Collector	Remarks
34	13.8	6.1	13.8	
	4.8	5.6	13.0	RX, AM only
35	6.1	6.5	13.8	RX
	5.6	6.2	13.0	TX, AM
	6.1	6.5	13.8	TX, SSB
36	2.7	3.3	6.3	RX
37	7.6	7.8	13.8	RX
	0	0.6	0	TX
38	0.6	1.3	8.0	TX
39	0	0.2	13.2	RX
	0	0.7	5.3	TX, AM
	0	0.7	13.8	TX, SSB
40	1.0	1.2	2.1	TX
41	0	0	13.2	RX
	0	0.7	5.3	TX, AM
	0	0.7	13.8	TX, SSB
42	2.8	3.5	8.0	RX

**FIELD EFFECT TRANSISTOR**

FET 1	Gate 0.2	Source 2.8	Drain 8.0
-------	----------	------------	-----------

**IC1 UHIC-070**

Pin No.	1	2	3	4	5	6	7	8	9	10
Voltage	7.8	0	0	0	5.4	0	0	8.0	7.3	4.0

**IC2 μPD-2824C**

Pin No.	1	2	3	4	5	6	7	8	9	10	11
Voltage	5.0	0	0	5.0	5.0	0	5.0	5.0	0.1	2.5	5.0
Pin No.	12	13	14	15	16	17	18	19	20	21	22
Voltage	2.5	2.5	2.5	5.0	5.0	2.5	2.5	5.2	5.0	0	2.5

**IC3 AN612**

Pin No.	1	2	3	4	5	6	7
Voltage	2.9	3.2	3.2	0	5.7	7.2	7.4

**IC4 TA7222P**

Pin No.	1	2	3	4	5	6	7	8	9	10
Voltage	13.8	2.9	0	0	1.8	1.8	0	0	6.8	13.1

**IC5 MB3756**

Pin No.	1	2	3	4	5	6	7	8
Voltage	8.0	13.8	8.0	0	13.8	8.0	-	0
Voltage	(8.0)	(13.8)	(8.0)	(0)	(0)	(0)	-	(8.0)

**IC6 SO42P**

Pin No.	1	2	3	4	5	6	7	8	9	10
Voltage	0	7.8	7.8	0	7.8	0	2.8	2.8	0	1.5
Pin No.	11	12	13	14						
Voltage	1.4	1.5	1.4	0						

Remarks: Voltages of IC6 were measured on transmit mode.

**IC EQUIVALENT CIRCUITS**

**UHIC007**

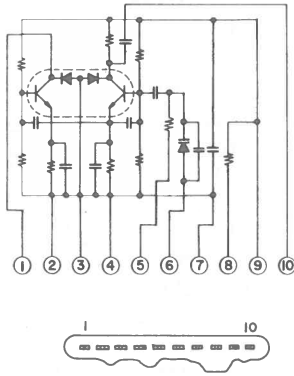

**μPD2824C**

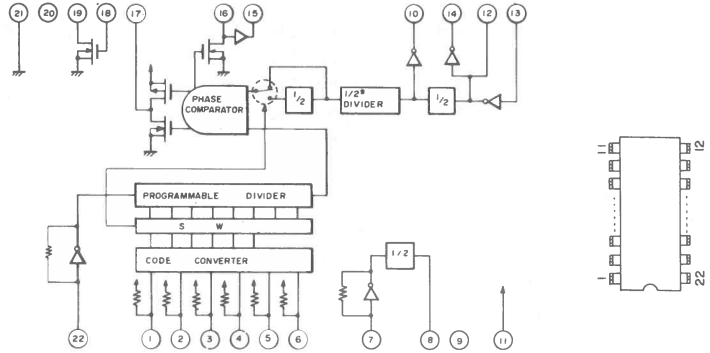

**SO42P**

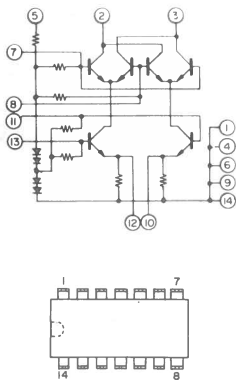

**TA7222P**

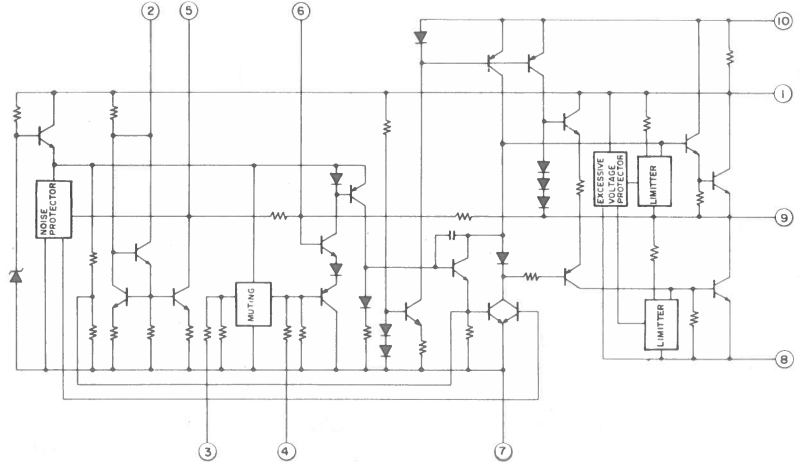

**MB3756**

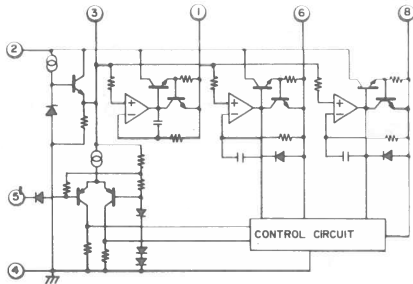

**AN612**

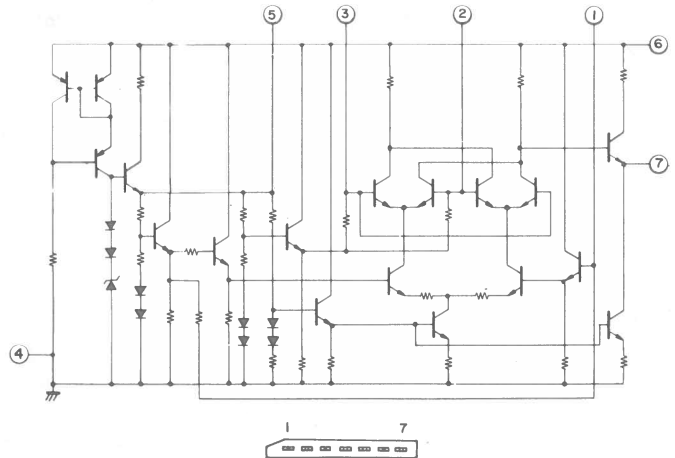



WARDS GEN-719A

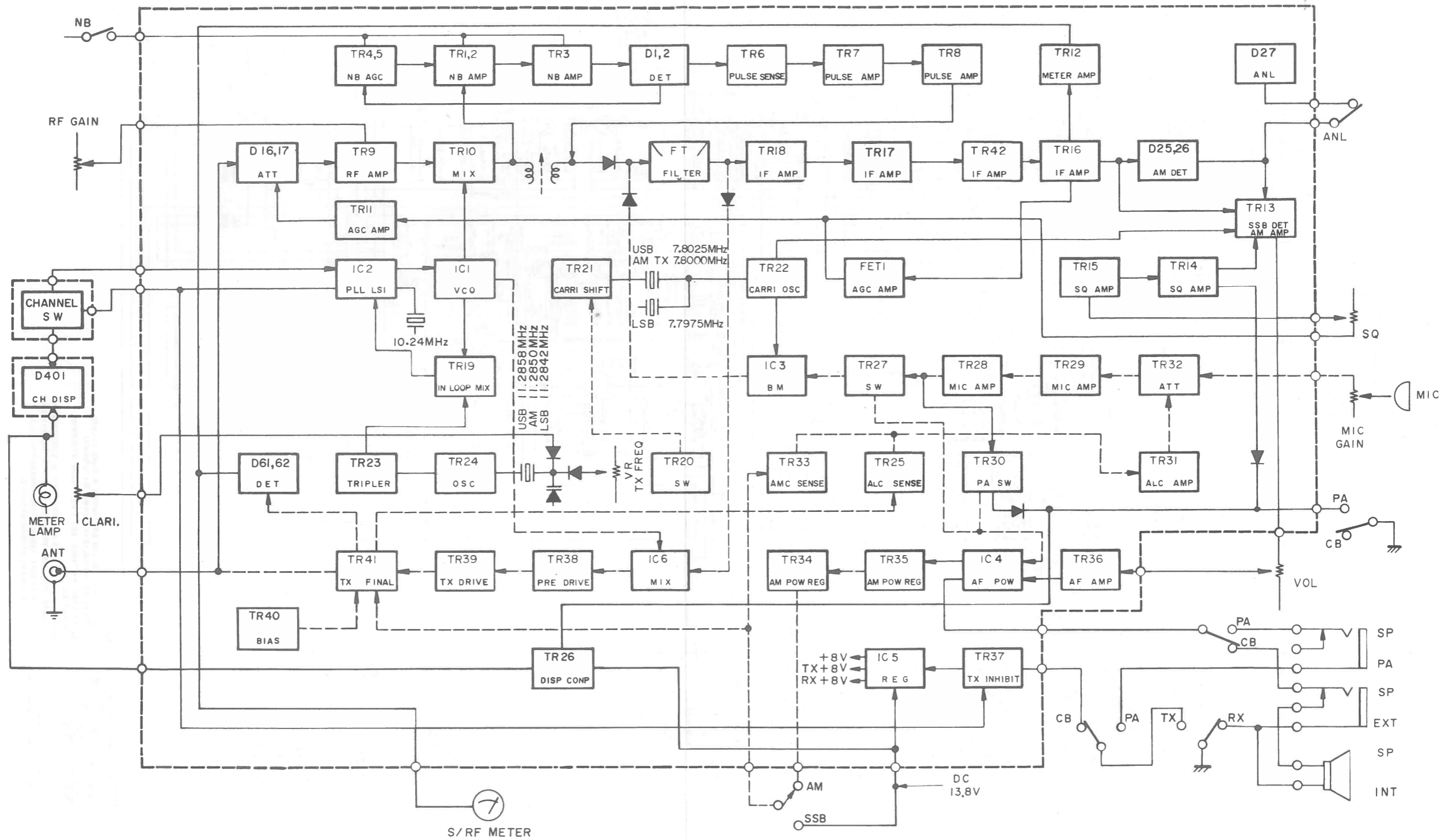

REF. NO.	PART NO.	DESCRIPTION	MFR PART CODE
<b>COILS AND TRANSFORMERS</b>			
L1	J611526	Coil, LA038	LLAY038001
L2	J611509	Coil, LA179	LLAY179001
L3	J611531	Coil, LA255	LLAY255001
L4	J611538	Coil, LA263	LLAY263001
L5	J611537	Coil, LA262	LLAY262001
L6	J611514	Coil, LA257	LLAY257001
L7	J611533	Coil, LA258	LLAY258001
L8	J611534	Coil, LA259	LLAY259001
L9	J611535	Coil, LA260	LLAY260001
L10	J611536	Coil, LA261	LLAY261001
L11, 15, 16, 21, 22, 23, 24	J611525	Inductor, Molded, LZ012 470 $\mu$ H	LLZY012004
L12, 25	J611524	Inductor, Molded, LZ012 100 $\mu$ H	LLZY012001
L13	J611510	Coil, LA216	LLAY216001
L14	J611528	Coil, LA195	LLAY195001
L17, 19	J611511	Coil, LA217	LLAY217001
L18	J611532	Coil, LA256	LLAY256001
L20	J611512	Coil, LA218	LLAY218001
L26	J611529	Coil, LA219	LLAY219001
L27	J611527	Coil, LA160	LLAY160001
L28	J611530	Coil, LA220	LLAY220001
L29	J611513	Coil, LA254	LLAY254001
L30	J611520	Coil, LD-096	LLDY096001
L31, 34	J611518	Coil, LD-087	LLDY087001
L32	J611522	Coil, LD-101	LLDY101001
L33, 35	J611521	Coil, LD-098	LLDY098001
L36, 39	J611515	Coil, LC-019	LLCY019001
L37, 38	J611523	Coil, LE-051	LLEY051001
L51, 52, 404, 405	J611517	Coil, LD-077	LLDY077001
L401, 402	J611516	Coil, LD-013	LLDY013001
L403	J611519	Coil, LD-089	LLDY089001
T1	J62996	Transformer, AF Choke, TF151	TTFY151001

REF. NO.	PART NO.	DESCRIPTION	MFR PART CODE
<b>SEMI-FIXED &amp; VARIABLE RESISTORS</b>			
VR1, 5, 7	J25941	Variable Resistor, 10 k ohm	RRVY182005
VR2	J25938	Variable Resistor, 1 k ohm	RRVY182002
VR3	J25939	Variable Resistor, 3 k ohm	RRVY182012
VR6, 9	J25940	Variable Resistor, 5 k ohm	RRVY182004
VR8	J25937	Variable Resistor, 500 ohm	RRVY182001
VR10	J25942	Variable Resistor, 100 k ohm	RRVY182008
VR401	J25945	Variable Resistor, 100 k ohm, Squelch (Inc. Nut/Washer)	RRVY126001
VR402	J25946	Variable Resistor, 20 k ohm, Clarifier (Inc. Nut/Washer)	RRVY139001
VR403 & S402	J25943	Variable Resistor, 10 k ohm, Volume (Inc. Nut/Washer W/S402)	RRVY008001
VR404	J25944	Variable Resistor, 10 k ohm, (RF Gain (Inc. Nut/Washer)	RRVY324001

### CRYSTALS

X1	J241295	Crystal, OSC. 10.24 MHz	QQXY077001
X2	J241297	Crystal, OSC. 7.8025 MHz	QQXY084001
X3	J241296	Crystal, OSC. 7.7975 MHz	QQXY083001
X4	J241298	Crystal, OSC. 11.2858 MHz	QQXY106001

### FIXED RESISTORS

R1, 160	CHF5318	Resistor, Carbon, Formed VERT, 18 k ohm 1/8W ±5%	RUBZ181834
R2, 17, 19, 23, 34, 61, 62, 82, 108, 109, 134, 159	CHF5233	Resistor, Carbon, Formed VERT, 3.3 k ohm 1/8W ±5%	RUBZ183324
R3, 59, 89, 126, 140	CHF5147	Resistor, Carbon, Formed VERT, 470 ohm 1/8W ±5%	RUBZ184714
R4, 8, 15, 175, 180, 403	CHF5133	Resistor, Carbon, Formed VERT, 330 ohm 1/8W ±5%	RUBZ183314
R5, 57, 60, 118, 149, 176	CHF5122	Resistor, Carbon, Formed VERT, 220 ohm 1/8W ±5%	RUBZ182214
R6, 30, 63, 70, 72, 107, 415	CHF5347	Resistor, Carbon, Formed VERT, 47 k ohm 1/8W ±5%	RUBZ184734
R7, 33	CHF5227	Resistor, Carbon, Formed VERT, 2.7 k ohm 1/8W ±5%	RUBZ182724
R9, 22, 67, 133	CHF5068	Resistor, Carbon, Formed VERT, 68 ohm 1/8W ±5%	RUBZ186804
R10, 74	CHF5447	Resistor, Carbon, Axial Lead, 470 k ohm 1/8W ±5%	RPBZ184744
R11, 24	CHF5447	Resistor, Carbon, Formed VERT, 470 k ohm 1/8W ±5%	RUBZ184744
R12, 13, 14, 16, 27, 31, 38, 45, 49, 80, 105, 106, 111, 116, 121, 147, 151, 152, 155, 161, 163	CHF5310	Resistor, Carbon, Formed VERT, 10 k ohm 1/8W ±5%	RUBZ181034
R18	CHF5218	Resistor, Carbon, Axial Lead, 1.8 k ohm 1/8W ±5%	RPBZ181824
R20, 35, 87, 124, 137	CHF5210	Resistor, Carbon, Axial Lead, 1 k ohm 1/8W ±5%	RPBZ181024
R21, 42, 123, 138, 418	CHF5247	Resistor, Carbon, Formed VERT, 4.7 k ohm 1/8W ±5%	RUBZ184724
R25, 153	CHF5218	Resistor, Carbon, Formed VERT, 1.8 k ohm 1/8W ±5%	RUBZ181824
R26, 47, 48, 51, 90, 95, 145, 174, 179, 182, 183, 191	CHF5110	Resistor, Carbon, Formed VERT, 100 ohm 1/8W ±5%	RUBZ181014

REF. NO.	PART NO.	DESCRIPTION	MFR PART CODE
<b>FIXED RESISTORS (Continued)</b>			
R28, 101, 401, 402, 404, 405, 406, 407, 408, 409, 410, 411, 412, 413	CHF5168	Resistor, Carbon, Formed VERT, 680 ohm 1/8W $\pm$ 5%	RUBZ186814
R29	CHF5347	Resistor, Carbon, Axial Lead, 47 k ohm 1/8W $\pm$ 5%	RPBZ184734
R32, 36, 39, 44, 68, 99, 104, 119, 135, 141, 146, 150, 164, 165, 197, 192	CHF5210	Resistor, Carbon, Formed VERT, 1 k ohm 1/8W $\pm$ 5%	RUBZ181024
R37, 85, 86, 100, 110, 122, 148	CHF5222	Resistor, Carbon, Formed VERT, 2.2 k ohm 1/8W $\pm$ 5%	RUBZ182224
R43, 131	CHF5239	Resistor, Carbon, Formed VERT, 3.9 k ohm 1/8W $\pm$ 5%	RUBZ183924
R46, 50	CHF5418	Resistor, Carbon, Formed VERT, 180 k ohm 1/8W $\pm$ 5%	RUBZ181844
R52, 54, 117, 166	CHF5215	Resistor, Carbon, Axial Lead, 1.5 k ohm 1/8W $\pm$ 5%	RUBZ181524
R53, 64, 88, 129, 144, 178	CHF5215	Resistor, Carbon, Formed VERT, 1.5 k ohm 1/8W $\pm$ 5%	RUBZ181524
R55, 196, 416	CHF5139	Resistor, Carbon, Formed VERT, 390 ohm 1/8W $\pm$ 5%	RUBZ183914
R56, 75, 84, 98	CHF5310	Resistor, Carbon, Axial Lead, 10 k ohm 1/8W $\pm$ 5%	RPBZ181034
R58	CHF53R3	Resistor, Carbon, Formed VERT, 3.3 ohm 1/8W $\pm$ 5%	RUBZ183394
R65, 97, 136, 158	CHF5156	Resistor, Carbon, Formed VERT, 560 ohm 1/8W $\pm$ 5%	RUBZ185614
R66, 130	CHF5115	Resistor, Carbon, Formed VERT, 150 ohm 1/8W $\pm$ 5%	RUBZ181514
R69, 71, 79, 103	CHF5410	Resistor, Carbon, Formed VERT, 100 k ohm 1/8W $\pm$ 5%	RUBZ181044
R81	CHF5268	Resistor, Carbon, Formed VERT, 6.8 k ohm 1/8W $\pm$ 5%	RUBZ186824
R83, 181	CHF5100	Resistor, Carbon, Axial Lead, 100 ohm 1/8W $\pm$ 5%	RPBZ181014
R91	CHF5115	Resistor, Carbon, Axial Lead, 150 ohm 1/8W $\pm$ 5%	RPBZ181514
R93	CHF5468	Resistor, Carbon, Formed VERT, 680 k ohm 1/8W $\pm$ 5%	RUBZ186844
R94	CHF5422	Resistor, Carbon, Formed VERT, 220 k ohm 1/8W $\pm$ 5%	RUBZ182244
R96	CHF5427	Resistor, Carbon, Formed VERT, 270 k ohm 1/8W $\pm$ 5%	RUBZ182744
R102, 114	CHF5315	Resistor, Carbon, Formed VERT, 15 k ohm 1/8W $\pm$ 5%	RUBZ181534
R112	CHF5333	Resistor, Carbon, Formed VERT, 33 k ohm 1/8W $\pm$ 5%	RUBZ183334
R113	CHF5522	Resistor, Carbon, Axial Lead, 2.2M ohm 1/8W $\pm$ 5%	RPBZ182254
R115	CHF5510	Resistor, Carbon, Formed VERT, 1M ohm 1/8W $\pm$ 5%	RUBZ181054
R120, 128, 142, 198	CHF5322	Resistor, Carbon, Formed VERT, 22 k ohm 1/8W $\pm$ 5%	RUBZ182234
R125	MC1110	Resistor, Metal Film, 100 ohm 1W $\pm$ 10%	RSJZ101015
R127	CHF5412	Resistor, Carbon, Formed VERT, 120 k ohm 1/8W $\pm$ 5%	RUBZ181244
R139	MC1122	Resistor, Metal Film, 220 ohm 1W $\pm$ 10%	RSJZ102215
R154	CHF5256	Resistor, Carbon, Formed VERT, 5.6 k ohm 1/8W $\pm$ 5%	RUBZ185624
R156	CBF5110	Resistor, Carbon, Axial Lead, 100 ohm 1/2W $\pm$ 5%	RPBZ121014
R157	CHF5322	Resistor, Carbon, Axial Lead, 22 k ohm 1/8W $\pm$ 5%	RPBZ182234
R162	CHF5282	Resistor, Carbon, Formed VERT, 8.2 k ohm 1/8W $\pm$ 5%	RUBZ188224
R172	CHF5010	Resistor, Carbon, Formed VERT, 10 ohm 1/8W $\pm$ 5%	RUBZ181004
R173	CHF5127	Resistor, Carbon, Axial Lead, 270 ohm 1/4W $\pm$ 5%	RPBZ142714
R177	CHF5012	Resistor, Carbon, Formed VERT, 12 ohm 1/8W $\pm$ 5%	RUBZ181204
R190	CBF5310	Resistor, Carbon, Axial Lead, 10 k ohm 1/2W $\pm$ 5%	RPBZ121034
R414	CHF5182	Resistor, Carbon, Formed VERT, 820 ohm 1/8W $\pm$ 5%	RUBZ188214
R417	CHF5227	Resistor, Carbon, Axial Lead, 2.7 k ohm 1/8W $\pm$ 5%	RPBZ182724

REF. NO.	PART NO.	DESCRIPTION	MFR PART CODE
----------	----------	-------------	------------------

## CAPACITORS

The code indicates variation of capacitance with temperature:

YA = ±5%, YB = ±10%, YD = +20 -30%, YE = +20 -50%, YF = +30 -80%, (-25 ~ +85°C), ZF = +30 -80% (-10 ~ +70°C), CH = 0±60ppm/°C, RH = -220ppm/°C±60ppm/°C, CJ = 0±120ppm/°C, RJ = -220ppm/°C±120ppm/°C, TH = -470ppm/°C±60ppm/°C, UJ = -750ppm/°C±120ppm/°C, SL = +350ppm/°C ~ -1000ppm/°C

C1, 2, 4, 5, 11, 14, 18, 50, 51, 52, 54, 55, 56, 57, 63, 92, 108, 196, 197, 205, 207, 208, 401, 402	CC .022U 50V 20	0.022MF +70% ~ -20% YF 50V Ceramic	CKGZ812230
C3, 6, 9, 31, 32, 33, 36, 41, 42, 44, 46, 79, 87, 98, 118, 193, 195, 403, 404, 405, 406, 407	CC .001U 50V 20	0.001MF ±20% YD 50V Ceramic	CKDZ811026
C7, 59, 128, 169	CM .047U 50V 10	0.047MF ±10% 50V Mylar	CQMZ814735
C8	CC 82P 50V 10 SL	82PF ±10% SL 50V Ceramic	CCGZ818205
C10, 12, 171	CC 330P 50V 10 SL	330PF ±10% SL 50V Ceramic	CCGZ813315
C13, 28, 120, 126, 166, 174	CM .1U 50V 10	0.1MF ±10% 50V Mylar	CQMZ811045
C15, 16, 93, 151	CE 2.2U 25V 75-10	2.2MF +70% ~ -20% 25V Electrolytic	CELZ512290
C17, 104, 117, 144	CE .47U 50V 75-10	0.47MF +70% ~ -20% 50V Electrolytic	CELZ814780
C19	CT .22U 25V20	0.22MF ±20% 25V Tantalum	CSEZ512286
C21	CC 5P 50V .25P SL	5PF ±0.25PF SL 50V Ceramic	CCGZ815091
C22	CC 3P 50V .25P SL	3PF ±0.25PF SL 50V Ceramic	CCGZ813091
C23, 149, 162	CC 1P 50V .25P SL	1PF ±0.25PF SL 50V Ceramic	CCGZ811091
C24, 26, 85, 103, 124, 170, 177	CE 47U 10V 75-10	47MF +70% ~ -20% 10V Electrolytic	CELZ114700
C25	CM .033U 50V 10	0.033MF ±10% 50V Mylar	CQMZ813335
C27	CE 22U 10V 75-10	22MF +70% ~ -20% 10V Electrolytic	CELZ112200
C30	CC 12P 50V 10 SL	12PF ±10% SL 50V Ceramic	CCGZ811205
C34, 60, 70, 130, 161, 173	CE 1U 50V 75-10	1MF +70% ~ -20% 50V Electrolytic	CELZ811090
C35, 37, 39, 168, 175, 176, 178, 180, 181, 190, 191, 192, 194, 201, 203	CC .0047U 50V 20	0.0047MF ±20% YD 50V Ceramic	CKDZ814726
C38, 88	CC 4P 50V .25P SL	4PF ±0.25PF SL 50V Ceramic	CCGZ814091
C40, 45, 49, 184	CC 2P 50V .25P NPO	2PF ±0.25PF CJ 50V Ceramic	CCBZ812091
C43, 111	CC 100P 50V 10 SL	100PF ±10% SL 50V Ceramic	CCGZ811015
C47	CC 56P 50V 10 SL	56PF ±10% SL 50V Ceramic	CCGZ815605
C48, 179	CC 33P 50V 10 SL	33PF ±10% SL 50V Ceramic	CCGZ813305
C53, 75, 82, 84, 86, 99, 109, 112, 115, 132, 133, 134, 135, 139, 140, 141, 148, 202, 204, 209	CC .01U 50V 20	0.01MF ±20% YD 50V Ceramic	CKDZ811036
C61	CM .022U 50V 10	0.022MF ±10% 50V Mylar	CQMZ812235
C62	CC 27P 50V 10 SL	27PF ±10% SL 50V Ceramic	CCGZ812705
C64, 101, 125	CM .001U 50V 10	0.001MF ±10% 50V Mylar	CQMZ811025
C65	CT 1U 25V 20	1MF ±20% 25V Tantalum	CSEZ511096
C67, 97, 100, 121, 185	CM .01U 50V 10	0.01MF ±10% 50V Mylar	CQMZ811035

REF. NO.	PART NO.	DESCRIPTION	MFR PART CODE
<b>CAPACITORS (Continued)</b>			
C68, 113	CC 18P 50V 10 NPO	18 PF $\pm$ 10% CH 50V Ceramic	CCCZ811805
C69	CC 12P 50V 5 NPO	12PF $\pm$ 10% CH 50V Ceramic	CCCZ811205
C71	CE 220U 6.3V 50-10	220MF +70% $\sim$ -20% 6.3V Electrolytic	CELZ902210
C73, 74	CT 2.2U 25V 20	2.2MF $\pm$ 20% 25V Tantalum	CSEZ512296
C76, 77, 164	CC 47P 50V 10 SL	47PF $\pm$ 10% SL 50V Ceramic	CCGZ814705
C78	CT 4.7U 10V 20	4.7MF $\pm$ 20% 10V Tantalum	CSEZ114796
C83	CC 15P 50V 10 NPO	15PF $\pm$ 10% CH 50V Ceramic	CCCZ811505
C89	CC 270P 50V 10 SL	270PF $\pm$ 10% SL 50V Ceramic	CCGZ812715
C91, 96	CM .0068U 50V 10	0.0068MF $\pm$ 10% 50V Mylar	QCMZ816825
C94	CE 100U 6.3V 50-10	100MF +70% $\sim$ -20% 6.3V Electrolytic	CELZ901010
C95	CM .0033U 50V 10	0.0033MF $\pm$ 10% 50V Mylar	QCMZ813325
C102, 131, 146	CE 10U 16V 75-10	10MF +70% $\sim$ -20% 16V Electrolytic	CELZ311000
C107	CE 1000U 10V 50-10	1000MF +70% $\sim$ -20% 10V Electrolytic	CELZ111020
C110, 137, 172	CC 470P 50V 10 SL	470PF $\pm$ 10% SL 50V Ceramic	CCGZ814715
C114, 150	CC 10P 50V .5P NPO	10PF $\pm$ 0.5PF CJ 50V Ceramic	CCBZ811002
C116	CE 220U 10V 50-10	220MF +70% $\sim$ -20% 10V Electrolytic	CELZ112210
C122	CE 4.7U 25V 75-10	4.7MF +70% $\sim$ -20% 25V Electrolytic	CELZ514790
C123	CT 22U 6.3V 20	22MF $\pm$ 20% 6.3V Tantalum	CSEZ902206
C127	CE 470U 10V 50-10	470MF +70% $\sim$ -20% 10V Electrolytic	CELZ114710
C129, 145	CE 10U 25V 50-10	10MF +70% $\sim$ -20% 25V Electrolytic	CELZ511000
C136	CC 10P 50V .5P SL	10PF $\pm$ 0.5PF SL 50V Ceramic	CCGZ811002
C138	CC 220P 50V 10 SL	220PF $\pm$ 10% SL 50V Ceramic	CCGZ812215
C147	CE 1000U 25V 50-10	1000MF +70% $\sim$ -20% 25V Electrolytic	CELZ511020
C158	CC 68P 50V 10 SL	68PF $\pm$ 10% SL 50V Ceramic	CCGZ816805
C159	CC 39P 50V 10 SL	39PF $\pm$ 10% SL 50V Ceramic	CCGZ813905
C160	CC 180P 50V 10 SL	180PF $\pm$ 10% SL 50V Ceramic	CCGZ811815
C163	CC 390P 50V 10 SL	390PF $\pm$ 10% SL 50V Ceramic	CCGZ813915
C165, 183	CC 330P 50V 10 N750	330PF $\pm$ 10% UJ 50V Ceramic	CCUZ813315
C167	CC 120P 50V 10 SL	120PF $\pm$ 10% SL 50V Ceramic	CCGZ811215
C182	CC 47P 50V 5 NPO	47PF $\pm$ 10% CH 50V Ceramic	CCCZ814705
C198	CC 18P 50V 10 SL	18PF $\pm$ 10% SL 50V Ceramic	CCGZ811805
C199	CC .047U 50V 20	0.047MF +70% $\sim$ -20% ZF 50V Ceramic	CKCZ814730
C206	CC .1U 25V 70-20	0.1MF +70% $\sim$ -20% ZF 25V Ceramic	CKCZ511040
CT1,2,3	J35517	CV-028 20PF Trimmer	CCVY028004

REF. NO.	PART NO.	DESCRIPTION	MFR PART CODE
<b>MISCELLANEOUS</b>			
PC621	J56693	PC Board Assembly, Main	PCB534Z621
PC381	J56694	PC Board Assembly, Channel Display	PCB534Z381
PC583	J56695	PC Board Assembly, Channel Select	PCB534Z583
PC587	J56696	PC Board Assembly, ANL/NB, PA/CB Switches	PCB534Z587
PC389	J56697	PC Board Assembly, Mic Jack	PCB534Z389
FT1	J241299	Filter, Crystal, FL065	FFLY065001
S401	J12752	Rotary Switch, Channel Selector (Inc. Nut/Washer)	SSRY219001
S402	N.A. Separately	Switch, Power (Part of Ref. No. VR403)	
S403-1,2	J12751	Rotary Switch, Mode Selector (Inc. Nut/Washer)	SSRY233001
S404	J12753	Switch, PA/CB	SSWY110001
S405	J12754	Switch, NB/ANL	SSWY097001
SP401	S-SE 3½ IN8Z3W	Speaker, 3½", 3W, Magnet Wt. 14.5 grams	ASPY050001
M401	J13111	Signal/Power Meter (w/LAMP, PL401)	ZMTY097001
	J63394	Microphone	AMKY124001
J401,402	J63396	Jack, P.A., Ext. Speaker JK-089	JJKY089001
J403	J261014	Power Supply Socket, JK052	JJKY052001
J404	J63395	Jack, Microphone, JK104	JJKY104001
J405	J261013	Antenna Connector, JK035	JJKY035001
TP7, 8	J261015	Terminal, Check Point	JTPY027001
F401	312004	Fuse, 4A, 250V, Fast Acting	ZFSY014003
YD033	J261016	Insulator, TR34 YD-033	ZYDY033001
YD039	J261017	Insulator, IC4 YD-039	ZYDY039001
YD040	J261018	Insulator, IC5 YD-040	ZYDY040001
YY027	J261019	Insulator, TR39, 41 YY027	ZYYY027001
YY039	J381608	Bushing (Ceramic), TR39, 41	ZYYY036001
	J92135	Power Supply Cord (w/Fuse Holder) and Plug, P-401)	WZDZ070235
FC1	J92138	Flat Cable, WF-011	WWFY011105
FC2	J92136	Flat Cable, WF-005	WWFY005101
FC3	J92137	Flat Cable, WF-005	WWFY005102
P401	N.A. Separately	Plug, Power Supply Cord (Part of Power Supply Cord)	
PL401	J18607	Pilot Lamp, Signal/Power Meter	PL401-534Z